

117

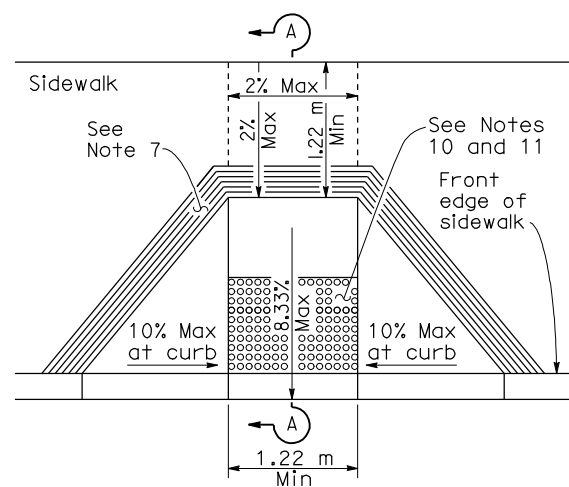

CASE A

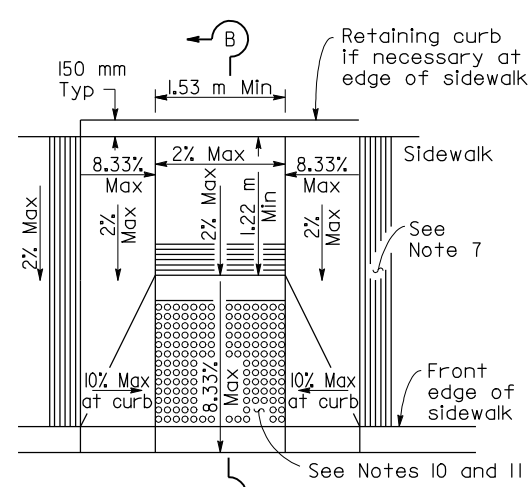

CASE B

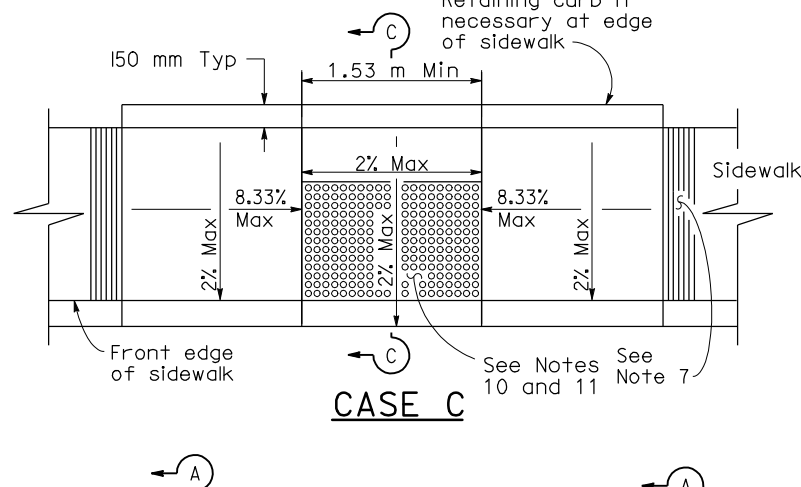

CASE C

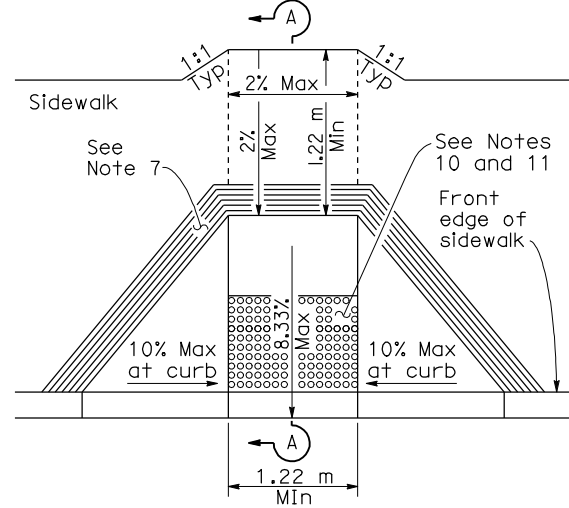

CASE D

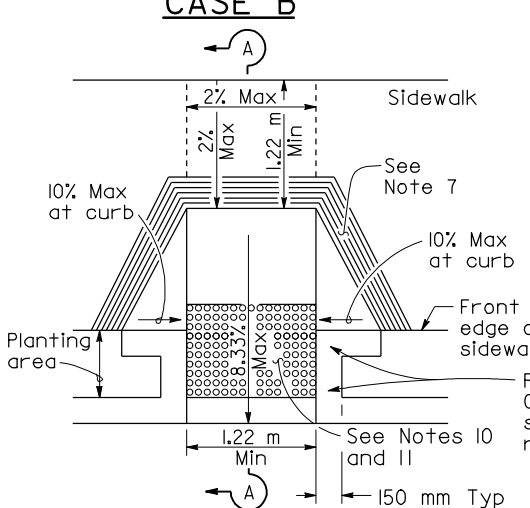

CASE E

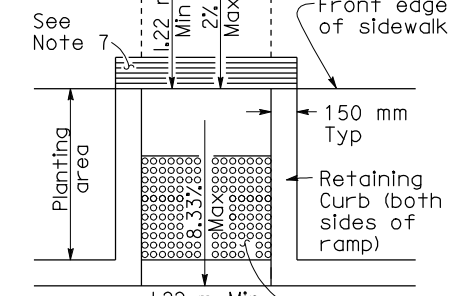

CASE F

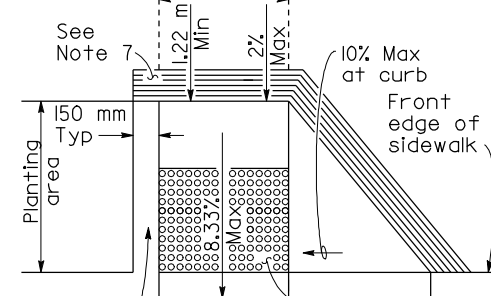

CASE G

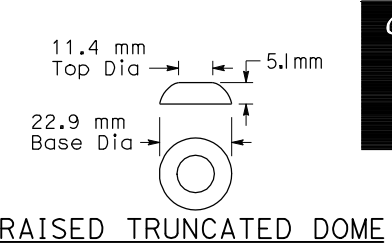

RAISED TRUNCATED DOME

NOTES

- As site conditions dictate, Case A through Case G curb ramps may be used for corner installations similar to those shown in Detail A and Detail B. The case of curb ramps used in Detail A do not have to be the same. Case A through Case G curb ramps also may be used at mid block locations, as site conditions dictate. For Cases B and C, the side of the curb ramp should always be perpendicular to curb face.
- If distance from curb to back of sidewalk is too short to accommodate ramp and 1.22 m platform (landing) as shown in Case A, the sidewalk may be depressed longitudinally as in Case B, or C or may be widened as in Case D.
- When ramp is located in center of curb return, crosswalk configuration must be similar to that shown for Detail B.
- As site conditions dictate, the retaining curb side and the flared side of the Case G ramp shall be constructed in reversed position.
- If located on a curve, the sides of the ramp need not be parallel, but the minimum width of the ramp shall be 1.22 m.
- Side slope of ramp flares vary uniformly from a maximum of 10% at curb to conform with longitudinal sidewalk slope adjacent to top of the ramp, except in Case C and Case F.
- The curb ramp shall be outlined, as shown, with a 305 mm wide border with 6 mm grooves approximately 19 mm on center. See grooving detail.
- Transitions from ramps and landings to walks, gutters or streets shall be flush and free of abrupt changes.
- Maximum slopes of adjoining gutters, the road surface immediately adjacent to the curb ramp, or accessible route shall not exceed 5 percent within 1.22 m of the top and bottom of the curb ramp.
- Curb ramps shall have a detectable warning surface that extends the full width and 914 mm depth of the ramp. Detectable Warning Surfaces shall conform to the details on this plan and the requirements in the Special Provisions.
- The edge of the detectable warning surface nearest the street shall be between 150 mm and 205 mm from the gutter flowline.
- Sidewalk and ramp thickness, "T", shall be 90 mm minimum.
- Utility pull boxes, manholes, vaults and all other utility facilities within the boundaries of the curb ramp will be relocated or adjusted to grade by the owner prior to, or in conjunction with, curb ramp construction.
- For retrofit conditions, removal and replacement of curb apron will be at the Contractor's option, unless otherwise shown on project plans.

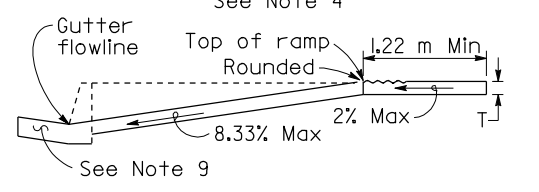

SECTION A-A

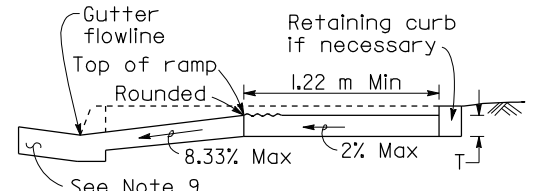

SECTION B-B

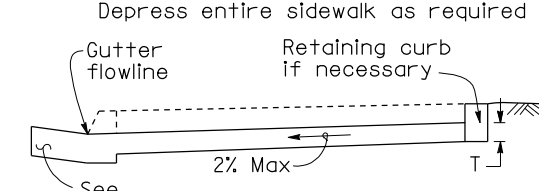

SECTION C-C

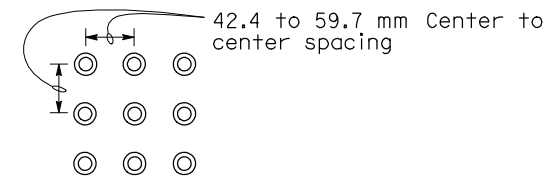

RAISED TRUNCATED DOME PATTERN (IN-LINE) DETECTABLE WARNING SURFACE

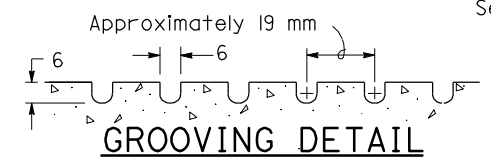

GROOVING DETAIL

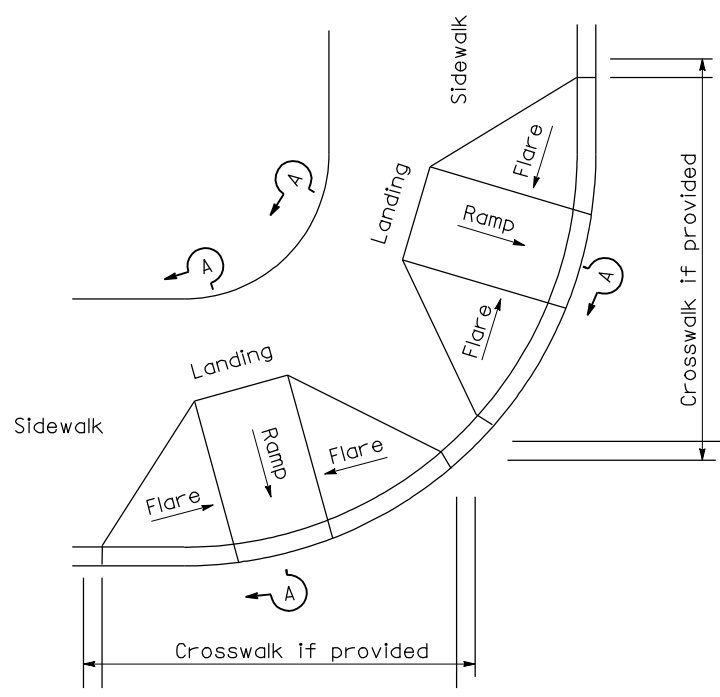

DETAIL A

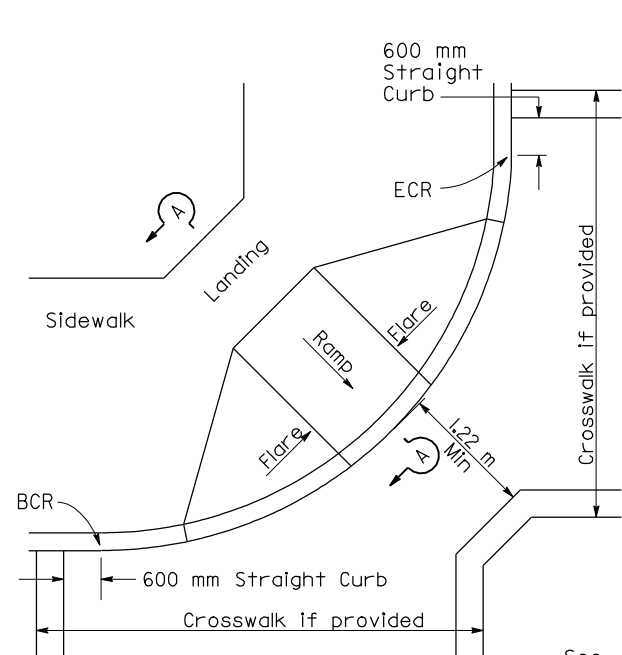

DETAIL B TYPICAL ONE-RAMP CORNER INSTALLATION

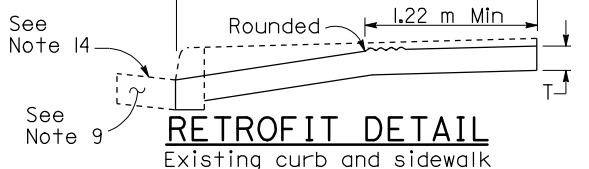

RETROFIT DETAIL Existing curb and sidewalk

TYPICAL TWO-RAMP CORNER INSTALLATION

See Note 1

See Notes 1 and 3

See Note 14
See Note 9

STATE OF CALIFORNIA DEPARTMENT OF TRANSPORTATION

CURB RAMP DETAILS

NO SCALE

ALL DIMENSIONS ARE IN MILLIMETERS UNLESS OTHERWISE SHOWN

RSP A88A DATED DECEMBER 16, 2005 SUPERSEDES STANDARD PLAN A88A DATED JULY 1, 2004-PAGE 117 OF THE STANDARD PLANS BOOK DATED JULY 2004.

REVISED STANDARD PLAN RSP A88A

2004 REVISED STD PLAN RSP A88A

DIST	COUNTY	ROUTE	KILOMETER TOTAL PROJECT	POST PROJECT	SHEET NO.	TOTAL SHEETS

Caltrans
Metric

H. David Cordova
REGISTERED CIVIL ENGINEER

December 16, 2005
PLANS APPROVAL DATE

Hector David Cordova
No. C41957
Exp. 3-31-06
CIVIL
STATE OF CALIFORNIA

The State of California or its officers or agents shall not be responsible for the accuracy or completeness of electronic copies of this plan sheet.

To get to the Caltrans web site, go to: <http://www.dot.ca.gov>